

軸用 同心型止め輪 (インチ)

軸に加工した溝に嵌め込み
溝からはみ出ている部分が受けとして働き
部品を固定。

USC 同心型止め輪

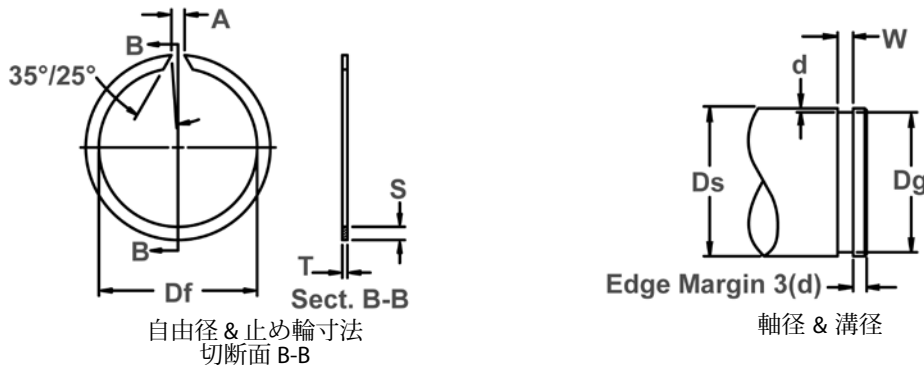

原材料: SAE 1060-1075

止め輪 番号	軸径			溝寸法				止め輪寸法					自由 間隙径 A		許容 静止時 荷重 (Lbs.)
				溝径		溝巾 W	深さ d	自由径		板厚 T	板幅				
	Ds DEC	Ds FRACT.	Ds mm	Dg	公差			Df	公差		+	-	S	公差	
USC-31	.312	5/16	7.92	.290			.011	.281		.025	.040		.031	.156	180
USC-34	.344	11/32	8.74	.322			.011	.312	+ .000	.025	.040		.031	.156	190
USC-35	.354	-	8.99	.330		.028	.012	.320	- .015	.025	.040		.031	.156	210
USC-37	.375	3/8	9.53	.351		+ .003	.012	.341		.025	.040		.031	.156	230
USC-39	.393	-	10.31	.369		- .000	.012	.359		.025	.040		.031	.156	260
USC-40	.406	13/32	11.13	.382			.012	.372	+ .000	.025	.040		.031	.156	280
USC-43	.438	7/16	11.91	.412			.013	.402	- .020	.025	.040		.031	.156	300
USC-46	.469	15/32	12.70	.443	+/- .002		.013	.433		.025	.040		.031	.156	320
USC-50	.500	1/2	14.00	.474			.013	.464		.035	.048		.062	.218	460
USC-55	.551	-	14.27	.524		.039	.013	.514		.035	.048		.062	.218	480
USC-56	.562	9/16	15.09	.534		+ .003	.014	.524		.035	.048		.062	.218	490
USC-59	.594	19/32	15.88	.566		- .000	.014	.555	+ .000	.035	.048		.062	.218	510
USC-62	.625	5/8	17.00	.597			.014	.586	- .025	.035	.062		.062	.218	520
USC-66	.669	-	17.00	.640			.015	.630		.035	.062	+/- .003	.062	.218	570
USC-68	.688	11/16	18.00	.656			.016	.644		.042	.062		.062	.218	700
USC-75	.750	3/4	19.05	.716			.017	.703		.042	.062		.062	.218	820
USC-78	.781	25/32	19.84	.745			.018	.733		.042	.062		.062	.218	950
USC-81	.812	13/16	20.62	.776		.046	.018	.764		.042	.062		.062	.218	1010
USC-87	.875	7/8	22.23	.835		+ .003	.020	.820		.042	.078		.093	.250	1100
USC-93	.938	15/16	23.83	.896		- .000	.021	.881		.042	.078		.093	.250	1130
USC-98	.984	63/64	25.00	.940			.022	.925		.042	.078		.093	.250	1170
USC-100	1.000	1	25.40	.956	+/- .003		.022	.941		.042	.093		.156	.312	1200
USC-102	1.023	-	25.98	.977			.023	.962	+ .000	.042	.093		.156	.312	1300
USC-106	1.062	1-1/16	26.97	1.016			.023	1.000	- .031	.050	.093		.156	.312	1600
USC-112	1.125	1-1/8	28.58	1.075			.025	1.060		.050	.093		.156	.312	1880
USC-118	1.188	1-3/16	30.18	1.136		.056	.026	1.121		.050	.093		.156	.312	1990
USC-125	1.250	1-1/4	31.75	1.194		+ .004	.028	1.179		.050	.093		.156	.312	2090
USC-131	1.312	1-5/16	33.32	1.25		- .000	.031	1.232		.050	.093		.156	.312	2100
USC-137	1.375	1-3/8	34.93	1.309	+/- .004		.033	1.291		.050	.109		.156	.312	2300
USC-143	1.438	1-7/16	36.53	1.370			.034	1.351		.050	.109		.156	.312	2460
USC-150	1.500	1-12	38.10	1.430			.035	1.408		.050	.109		.156	.312	2500

単位: inch

硬さ: 全サイズ: HRC 42 ~ 53

その他の先端部形状をご希望の場合は、japan@rotorclip.comまでお問い合わせ下さい。



軸に加工した溝に嵌め込み
溝からはみ出ている部分が受けとして働き
部品を固定。

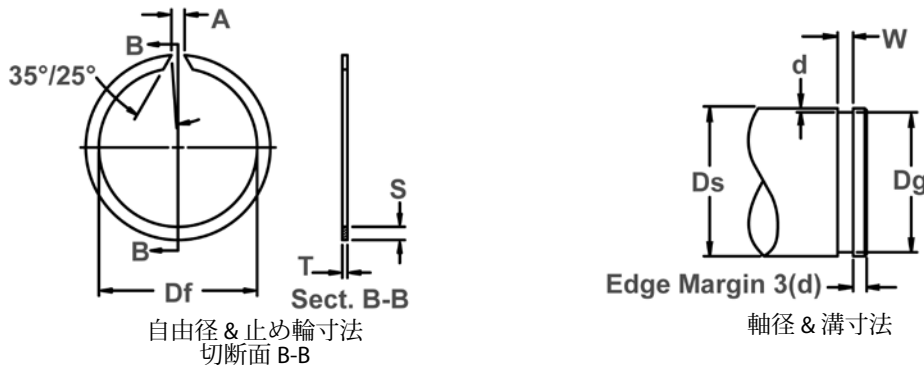

原材料: SAE 1060-1075

止め輪 番号	軸径			溝寸法			止め輪寸法						許容 静止時 荷重 (Lbs.)		
				溝径		溝巾	深さ	自由径		板厚	板幅			自由 間隙径 A	
	Ds DEC	Ds FRACT.	Ds mm	Dg	公差	W	d	Df	公差	+/- .002 T	S	公差		最小	最大
USC-156	1.562	1-9/16	39.67	1.490	+/- .004	.068 +.004 -.000	.036	1.467	+.000 -.046	.062	.125	+/- .005	.156	.375	3060
USC-162	1.625	1-5/8	41.28	1.551			.037	1.527		.062	.125		.156	.375	3190
USC-168	1.688	1-11/16	42.90	1.611			.038	1.581		.062	.125		.156	.375	3370
USC-175	1.750	1-3/4	44.40	1.670			.04	1.640		.062	.125		.156	.375	3510
USC-177	1.772	-	45.00	1.687			.042	1.657		.062	.141		.156	.375	3550
USC-181	1.812	1-13/16	46.00	1.728			.042	1.698		.062	.141		.156	.375	3640
USC-187	1.875	1-7/8	47.60	1.789			.043	1.759		.062	.156		.156	.375	3760
USC-196	1.969	1-31/32	50.00	1.879			.045	1.849		.062	.156		.156	.375	3940
USC-200	2.000	2	50.80	1.910			.045	1.880		.062	.156		.156	.375	4010
USC-206	2.062	2-1/16	52.40	1.966			.048	1.936		.078	.156		.156	.375	5350
USC-212	2.125	2-1/8	54.00	2.027	.049	1.997	.078	.156	.156	.375	5470				
USC-215	2.156	2-5/32	54.80	2.056	.050	2.026	.078	.156	.156	.375	5680				
USC-225	2.250	2-1/4	57.10	2.146	.052	2.116	.078	.156	.156	.375	5790				
USC-231	2.312	2-5/16	58.70	2.204	.054	2.174	.078	.187	.156	.375	6300				
USC-237	2.375	2-3/8	60.30	2.265	.055	2.235	.078	.187	.156	.375	6400				
USC-243	2.438	2-7/16	61.90	2.325	.056	2.295	.078	.187	.156	.375	6500				
USC-250	2.500	2-1/2	63.50	2.386	.057	2.356	.078	.187	.156	.375	6600				
USC-255	2.559	-	65.00	2.443	.058	2.413	.078	.187	.156	.375	6700				
USC-262	2.625	2-5/8	66.70	2.505	.060	2.475	.078	.187	.156	.375	6800				
USC-268	2.688	2-11/16	68.30	2.565	.061	2.535	.078	.187	.156	.375	6900				
USC-275	2.750	2-3/4	69.80	2.624	.063	2.594	.093	.187	.187	.437	8460				
USC-287	2.875	2-7/8	73.00	2.743	.066	2.713	.093	.187	.187	.437	8840				
USC-293	2.938	2-15/16	74.60	2.801	.068	2.771	.093	.187	.187	.437	9030				
USC-300	3.000	3	76.20	2.860	.070	2.830	.093	.218	.187	.437	9230				
USC-306	3.062	3-1/16	77.80	2.920	.071	2.890	.093	.218	.187	.437	9420				
USC-312	3.125	3-1/8	79.40	2.981	.072	2.951	.093	.218	.187	.437	9630				
USC-315	3.156	3-5/32	80.20	3.010	.073	2.980	.093	.218	.187	.437	9800				
USC-325	3.250	3-1/4	82.50	3.100	.075	3.070	.093	.250	.187	.437	10000				
USC-334	3.346	3-11/32	85.00	3.190	.077	3.160	.093	.250	.187	.437	10290				
USC-343	3.438	3-7/16	87.3	3.281	.078	3.251	.093	.250	.187	.437	10570				

単位: inch

硬さ: 全サイズ: HRC 42 ~ 53

その他の先端部形状をご希望の場合は、japan@rotorclip.comまでお問い合わせ下さい。



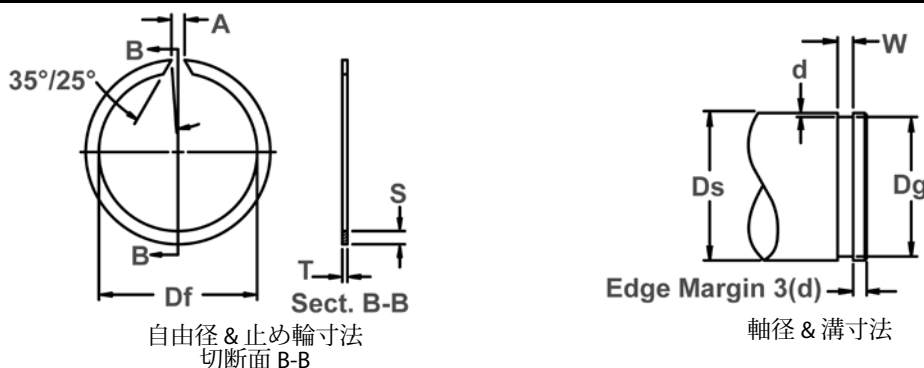

原材料: SAE 1060-1075

止め輪 番号	軸径			溝寸法			止め輪寸法					許容 静止時 荷重 (Lbs.)			
				溝径		溝巾	深さ	自由径		板厚	板幅		自由 間隙径 A		
	Ds DEC	Ds FRACT.	Ds mm	Dg	公差	W	d	Df	公差	T +/- .002	S		公差	最小	最大
USC-350	3.500	3-1/2	88.9	3.340	+/- .006	.120 +.005 -.000	.080	3.305	+.000 -.078	.109	.250	+/- .005	.250	.562	11970
USC-354	3.543	-	90.0	3.381			.081	3.346		.109	.250		.250	.562	12120
USC-362	3.625	3-5/8	92.1	3.458			.083	3.423		.109	.250		.250	.562	12300
USC-368	3.688	3-11/16	93.7	3.517			.085	3.482		.109	.250		.250	.562	12600
USC-375	3.750	3-3/4	95.2	3.576			.087	3.541		.109	.250		.250	.562	12800
USC-387	3.875	3-7/8	98.4	3.697			.089	3.657		.109	.281		.250	.562	13200
USC-393	3.938	3-15/16	100.0	3.758			.090	3.713		.109	.281		.250	.562	13470
USC-400	4.000	4	101.6	3.816			.092	3.771		.109	.281		.250	.656	13650
USC-425	4.250	4-1/4	108.0	4.066			.092	4.016		.109	.281		.250	.656	15000
USC-437	4.375	4-3/8	111.1	4.191			.092	4.141		.109	.281		.250	.656	15500
USC-450	4.500	4 1/2	114.3	4.310	.095	4.255	.109	.312	.250	.656	16200				
USC-475	4.750	4-3/4	120.6	4.550	.100	4.495	.109	.312	.250	.656	16480				
USC-500	5.000	5	127.0	4.790	.105	4.730	.109	.312	.250	.656	17110				
USC-525	5.250	5-1/4	133.3	5.030	.110	4.970	.125	.375	.250	.750	20590				
USC-550	5.500	5-1/2	139.7	5.266	.117	5.206	.125	.375	.250	.750	21790				
USC-575	5.750	5-3/4	146.0	5.506	.122	5.446	.125	.375	.250	.750	23010				
USC-590	5.900	-	149.9	5.656	.122	5.600	.125	.375	.250	.750	23625				
USC-600	6.000	6	152.4	5.746	.127	5.687	.125	.375	.250	.750	24000				
USC-625	6.250	6-1/4	158.7	5.986	.132	5.916	.156	.437	.250	.750	30310				
USC-650	6.500	6-1/2	165.1	6.226	.174	.137	6.151	.156	.437	.250	.750	33760			
USC-675	6.750	6-3/4	171.4	6.466	.142	6.386	.156	.437	.250	.750	36840				
USC-700	7.000	7	177.8	6.706	.147	6.621	.156	.437	.250	.750	39920				
USC-725	7.250	7-1/4	184.2	6.930	.160	6.840	.187	.500	.250	.875	43100				
USC-750	7.500	7-1/2	190.5	7.180	.160	7.090	.187	.500	.250	.875	44500				
USC-800	8.000	8	203.2	7.660	.170	7.560	.187	.500	.250	.875	45500				
USC-850	8.500	8-1/2	215.9	8.160	.170	8.050	.187	.500	.250	.875	46700				
USC-900	9.000	9	228.6	8.660	.170	8.545	.187	.500	.250	.875	49900				
USC-925	9.250	9-1/4	234.9	8.910	.170	8.800	.187	.500	.250	.875	51000				
USC-950	9.500	9-1/2	241.3	9.160	.170	9.040	.187	.500	.250	.875	52590				
USC-1000	10.000	10	254.0	9.660	.170	9.535	.187	.500	.250	.875	55600				

単位: inch

硬さ: 全サイズ: HRC 42 ~ 53

その他の先端部形状をご希望の場合は、japan@rotorclip.comまでお問い合わせ下さい。

